



# EKSPLOATĀCIJAS ĪPAŠĪBU DEKLARĀCIJA

Nr: 18-EUS2-A4-HCR [LV]

# ESSVE

GET IT DONE

Unikālais izstrādājuma tipa identifikācijas numurs:

Pants numurs	Apraksts	ETA-18/1138	ETA-24/1152
10004642	CONCRETE SCREW EUS2-HF HEX FLANGE ZINC FLAKE 7,5(6)X60	✓	✓
10004643	CONCRETE SCREW EUS2-HF HEX FLANGE ZINC FLAKE 7,5(6)X80	✓	✓
10004644	CONCRETE SCREW EUS2-HF HEX FLANGE ZINC FLAKE 7,5(6)X100	✓	✓
10004645	CONCRETE SCREW EUS2-HF HEX FLANGE ZINC FLAKE 10,5(8)X50	✓	-
10004647	CONCRETE SCREW EUS2-HF HEX FLANGE ZINC FLAKE 10,5(8)X70	✓	-
10004649	CONCRETE SCREW EUS2-HF HEX FLANGE ZINC FLAKE 10,5(8)X90	✓	-
10004651	CONCRETE SCREW EUS2-HF HEX FLANGE ZINC FLAKE 10,5(8)X120	✓	-
10004653	CONCRETE SCREW EUS2-HF HEX FLANGE ZINC FLAKE 12,5(10)X60	✓	-
10004655	CONCRETE SCREW EUS2-HF HEX FLANGE ZINC FLAKE 12,5(10)X80	✓	-
10004657	CONCRETE SCREW EUS2-HF HEX FLANGE ZINC FLAKE 12,5(10)X100	✓	-
10004658	CONCRETE SCREW EUS2-HF HEX FLANGE ZINC FLAKE 12,5(10)X120	✓	-
10004661	CONCRETE SCREW EUS2-HF HEX FLANGE ZINC FLAKE 12,5(10)X160	✓	-
10004662	CONCRETE SCREW EUS2-HF HEX FLANGE ZINC FLAKE 12,5(10)X180	✓	-
10004663	CONCRETE SCREW EUS2-HF HEX FLANGE ZINC FLAKE 12,5(10)X200	✓	-
10004664	CONCRETE SCREW EUS2-HF HEX FLANGE ZINC FLAKE 12,5(10)X240	✓	-
10004673	CONCRETE SCREW EUS2-HF HEX FLANGE ZINC FLAKE 16,5(14)X80	✓	-
10004674	CONCRETE SCREW EUS2-HF HEX FLANGE ZINC FLAKE 16,5(14)X110	✓	-
10004685	CONCRETE SCREW EUS2-HF HEX FLANGE ZINC PLATED 10,5(8)X50	✓	-
10004687	CONCRETE SCREW EUS2-HF HEX FLANGE ZINC PLATED 10,5(8)X70	✓	-
10004689	CONCRETE SCREW EUS2-HF HEX FLANGE ZINC PLATED 10,5(8)X90	✓	-
10004691	CONCRETE SCREW EUS2-HF HEX FLANGE ZINC PLATED 10,5(8)X120	✓	-
10004692	CONCRETE SCREW EUS2-HF HEX FLANGE ZINC PLATED 10,5(8)X140	✓	-
10004693	CONCRETE SCREW EUS2-HF HEX FLANGE ZINC PLATED 12,5(10)X60	✓	-
10004695	CONCRETE SCREW EUS2-HF HEX FLANGE ZINC PLATED 12,5(10)X80	✓	-
10004697	CONCRETE SCREW EUS2-HF HEX FLANGE ZINC PLATED 12,5(10)X100	✓	-
10004698	CONCRETE SCREW EUS2-HF HEX FLANGE ZINC PLATED 12,5(10)X120	✓	-
10004713	CONCRETE SCREW EUS2-HF HEX FLANGE ZINC PLATED 16,5(14)X80	✓	-
10004714	CONCRETE SCREW EUS2-HF HEX FLANGE ZINC PLATED 16,5(14)X110	✓	-



# EKSPLOATĀCIJAS ĪPAŠĪBU DEKLARĀCIJA

Nr: 18-EUS2-A4-HCR [LV]

## ESSVE

GET IT DONE

Unikālais izstrādājuma tipa identifikācijas numurs:

Pants numurs	Apraksts	ETA-18/1138	ETA-24/1152
10000273	CONCRETE SCREW EUSA4-C COUNTERSUNK 7,5(6)X65 A4 CE	✓	✓
10000274	CONCRETE SCREW EUSA4-C COUNTERSUNK 7,5(6)X85 A4 CE	✓	✓
10000275	CONCRETE SCREW EUSA4-C COUNTERSUNK 7,5(6)X105 A4 CE	✓	✓
105810	CONCRETE SCREW EUSA4-HF HEX FLANGE 10,5(8)X70 A4 CE	✓	-
105815	CONCRETE SCREW EUSA4-HF HEX FLANGE 10,5(8)X80 A4 CE	✓	-
105820	CONCRETE SCREW EUSA4-HF HEX FLA. 12,5(10)X90 A4 CE	✓	-
105825	CONCRETE SCREW EUSA4-HF HEX FLA. 12,5(10)X100 A4 CE	✓	-
105830	CONCRETE SCREW EUSA4-C CSK. 10,5(8)X80 A4 CE	✓	-
105835	CONCRETE SCREW EUSA4-C CSK. 12,5(10)X90 A4 CE	✓	-

Ražotājs:

ESSVE

BOX 7091

164 07 Kista

Sweden

Eiropas tehniskais novērtējums (ETA)	Paredzētais izmantojums	Ārējais diametrs un (urbuma) izmērs [mm]
ETA-18/1138 (2019-02-13)	<ul style="list-style-type: none"><li>Single anchor or anchor groups for use in structural applications under static or quasi-static actions in cracked and uncracked concrete.</li><li>Installation with adjustment (ETA Annex B 4)</li><li>Resistance to Fire for all embedment depths and dimensions</li><li>Seismic resistance for maximum embedment depth</li></ul>	7,5(6)
		10,6(8)
		12,6(10)
		14,6(12)
		16,6(14)
ETA-24/1152 (2025-01-13)	<ul style="list-style-type: none"><li>Anchors used in redundant non-structural systems under static or quasi-static actions in cracked and uncracked concrete.</li><li>Resistance to Fire for all embedment depths and dimensions in solid concrete (not in prestressed hollow slabs)</li></ul>	6,5(5)
		7,5(6)
ETA-24/1152 (2025-01-13)	<ul style="list-style-type: none"><li>Anchors used in redundant non-structural systems in prestressed hollow core slabs C30/37 to C50/60 under static or quasi-static actions</li></ul>	7,5(6)

Eiropas tehniskais novērtējums (ETA)	Ekspluatācijas īpašību noturības novērtējuma un pārbaudes (AVCP) sistēma	Eiropas novērtējuma dokuments	Tehniskā novērtējuma iestāde (TAB)	Paziņotā(-ās) iestāde(-es) (NB)
ETA-18/1138 (2019-02-13)	1	EAD 330232-00-0601, (2016-10)	Deutsches Institut für Bautechnik (DIBt)	2873 (FPC)
ETA-18/1138 (2019-02-13)	1	EAD 330011-00-0601, (2015-03)	Deutsches Institut für Bautechnik (DIBt)	2873 (FPC)
ETA-24/1152 (2025-01-13)	2+	EAD 330747-00-0601, (2018-06)	Deutsches Institut für Bautechnik (DIBt)	2873 (FPC)



# EKSPLOATĀCIJAS ĪPAŠĪBU DEKLARĀCIJA

Nr: 18-EUS2-A4-HCR [LV]

**ESSVE**  
GET IT DONE

Eiropas tehniskais novērtējums (ETA)	Būtiskie raksturlielumi	Ekspluatācijas īpašības
ETA-18/1138 (2019-02-13)	Characteristic resistance under static and quasi-static loading	ETA-18/1138 Annex C 1 & Annex C 2
	Displacements (static and quasi-static loading)	ETA-18/1138 Annex C 3
	Characteristic resistance and displacements for seismic performance category C1	ETA-18/1138 Annex C 4
	Reaction to fire	Class A1
	Resistance to fire	ETA-18/1138 Annex C 5
ETA-24/1152 (2025-01-13)	Reaction to fire	Class A1
	Resistance to fire	ETA-24/1152 Annex C3
	Characteristic resistance to tension load (static and quasi-static loading)	ETA-24/1152 Annex B2, Annex C1, Annex C2
	Characteristic resistance to shear load (static and quasi-static loading)	ETA-24/1152 Annex C1, Annex C2
	Durability	ETA-24/1152 Annex B1

Iepriekš norādītā izstrādājuma ekspluatācijas īpašības atbilst deklarēto ekspluatācijas īpašību kopumam. Šī ekspluatācijas īpašību deklarācija izdota saskaņā ar Regulu (ES) Nr. 305/2011, un par to ir atbildīgs vienīgi iepriekš norādītais ražotājs.

Parakstīts ražotāja vārdā:

Viktor Bukowski

Product Manager – Concrete Fasteners

Kista 2025-01-16

[ETA attached as an appendix]

Approval body for construction products  
and types of construction

Bautechnisches Prüfamt

An institution established by the Federal and  
Laender Governments



## European Technical Assessment

ETA-18/1138  
of 13 February 2019

English translation prepared by DIBt - Original version in German language

### General Part

Technical Assessment Body issuing the  
European Technical Assessment:

Deutsches Institut für Bautechnik

Trade name of the construction product

EUS2, EUSA4, EUSHCR

Product family  
to which the construction product belongs

Mechanical fastener for use in concrete

Manufacturer

ESSVE Produkter AB  
Esbogatan 14  
164 74 KISTA  
SCHWEDEN

Manufacturing plant

ESSVE plants

This European Technical Assessment  
contains

16 pages including 3 annexes which form an integral part  
of this assessment

This European Technical Assessment is  
issued in accordance with Regulation (EU)  
No 305/2011, on the basis of

EAD 330232-00-0601  
EAD 330011-00-0601

The European Technical Assessment is issued by the Technical Assessment Body in its official language. Translations of this European Technical Assessment in other languages shall fully correspond to the original issued document and shall be identified as such.

Communication of this European Technical Assessment, including transmission by electronic means, shall be in full. However, partial reproduction may only be made with the written consent of the issuing Technical Assessment Body. Any partial reproduction shall be identified as such.

This European Technical Assessment may be withdrawn by the issuing Technical Assessment Body, in particular pursuant to information by the Commission in accordance with Article 25(3) of Regulation (EU) No 305/2011.

## Specific Part

### 1 Technical description of the product

The ESSVE Concrete Screw EUS2, EUSA4 and EUSHCR is an anchor in size 6, 8, 10, 12 and 14 mm made of galvanised steel respectively steel with zinc flake coating, made of stainless or high corrosion resistant steel. The anchor is screwed into a predrilled cylindrical drill hole. The special thread of the anchor cuts an internal thread into the member while setting. The anchorage is characterised by mechanical interlock in the special thread.

Product and product description is given in Annex A.

### 2 Specification of the intended use in accordance with the applicable European Assessment Document

The performances given in Section 3 are only valid if the anchor is used in compliance with the specifications and conditions given in Annex B.

The verifications and assessment methods on which this European Technical Assessment is based lead to the assumption of a working life of the anchor of at least 50 years. The indications given on the working life cannot be interpreted as a guarantee given by the producer, but are to be regarded only as a means for choosing the right products in relation to the expected economically reasonable working life of the works.

### 3 Performance of the product and references to the methods used for its assessment

#### 3.1 Mechanical resistance and stability (BWR 1)

Essential characteristic	Performance
Characteristic resistance to tension load (static and quasi-static loading)	See Annex C 1 and C 2
Characteristic resistance to shear load (static and quasi-static loading)	See Annex C 1 and C 2
Displacements (static and quasi-static loading)	See Annex C 3
Characteristic resistance and displacements for seismic performance category C1	See Annex C 4

#### 3.2 Safety in case of fire (BWR 2)

Essential characteristic	Performance
Reaction to fire	Class A1
Resistance to fire	See Annex C 5

**4 Assessment and verification of constancy of performance (AVCP) system applied, with reference to its legal base**

In accordance with European Assessment Documents EAD No. 330232-00-0601 and EAD No. 330011-00-0601, the applicable European legal act is: [96/582/EC].

The system to be applied is: 1

**5 Technical details necessary for the implementation of the AVCP system, as provided for in the applicable EAD**

Technical details necessary for the implementation of the AVCP system are laid down in the control plan deposited with Deutsches Institut für Bautechnik.

Issued in Berlin on 13 February 2019 by Deutsches Institut für Bautechnik

BD Dipl.-Ing. Andreas Kummerow  
Head of Department

*beglaubigt:*  
Tempel

**Product and installed condition**

**ESSVE concrete screw EUS2, EUSA4, EUSHCR**

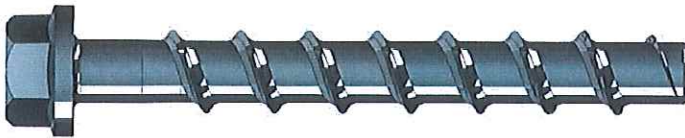

**carbon steel**



**stainless steel A4 and HCR**

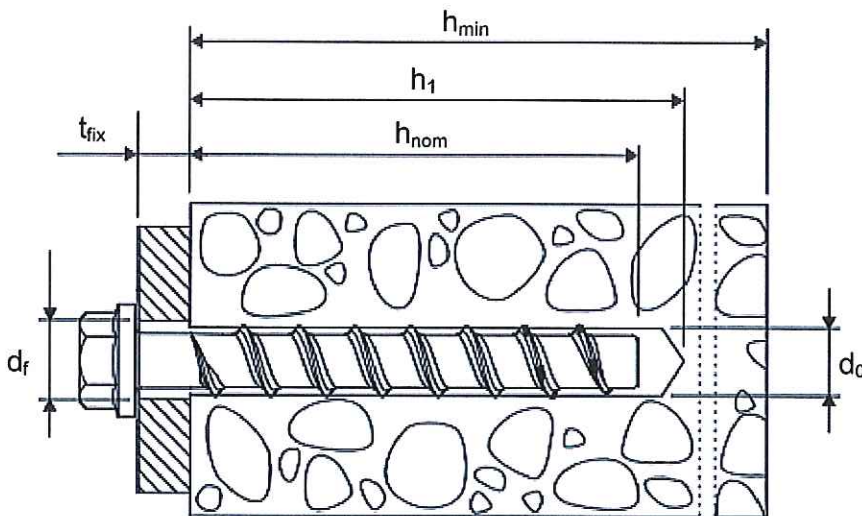

- |           |   |   |
|-----------|---|---|
| $d_0$     | = | nominal drill bit diameter                |
| $h_{nom}$ | = | nominal anchorage depth                   |
| $h_1$     | = | depth of the drill hole                   |
| $h_{min}$ | = | minimum thickness of member               |
| $t_{fix}$ | = | thickness of fixture                      |
| $d_r$     | = | diameter of clearance hole in the fixture |

**ESSVE concrete screw EUS2, EUSA4, EUSHCR**























**Product description**

Installed condition

**Annex A 1**

**Table A1: Materials and variants**

part	name	Material				
1, 2, 3, 4, 5, 6, 7, 8, 9, 10, 11	Concrete screw	EUS2	Steel EN 10263-4:2017 galvanized acc. to EN ISO 4042:2018 or zinc flake coating acc. to EN ISO 10683:2018 ( $\geq 5\mu\text{m}$ )			
			EUSA4	1.4401, 1.4404, 1.4571, 1.4578		
			EUSHCR	1.4529		
						EUS2, EUSA4, EUSHCR
		nominal characteristic steel yield strength		$f_{yk}$	[N/mm <sup>2</sup> ]	560
		nominal characteristic steel ultimate strength		$f_{uk}$	[N/mm <sup>2</sup> ]	700
		elongation at rupture		$A_5$	[%]	$\leq 8$

		1)	Anchor version with connection thread and hexagon socket e.g. EUS2 8x105 M10 SW5
		2)	Anchor version with connection thread and hexagon drive e.g. EUS2 8x105 M10 SW7
		3)	Anchor version with washer, hexagon head and TORX e.g. EUS2-HF 8x80 SW13 TX40
		4)	Anchor version with washer and hexagon head e.g. EUS2-HF 8x80 SW13
		5)	Anchor version with hexagon head e.g. EUS2-H 8x80 SW13
		6)	Anchor version with countersunk head e.g. EUS2-C 8x80 TX40
		7)	Anchor version with pan head e.g. EUS2-PS 8x80 TX40
		8)	Anchor version with large pan head e.g. EUS2-PL 8x80 TX40
		9)	Anchor version with countersunk head and connection thread e.g. EUS2-E 6x55 M8
		10)	Anchor version with hexagon drive and connection thread e.g. EUS2-E 6x55 SW10
		11)	Anchor version with internal thread and hexagon drive e.g. EUS2-I 6x55 M8/10

ESSVE concrete screw EUS2, EUSA4, EUSHCR

Product descriptions

Materials and variants

Annex A 2

**Table A2: Dimensions and markings**

Anchor size EUS2, EUSA4, EUSHCR		6		8			10			
Nominal embedment depth $h_{nom}$ [mm]		$h_{nom1}$	$h_{nom2}$	$h_{nom1}$	$h_{nom2}$	$h_{nom3}$	$h_{nom1}$	$h_{nom2}$	$h_{nom3}$	
		40	55	45	55	65	55	75	85	
Length of the anchor $L \leq$	[mm]	500								
Diameter of shaft $d_k$	[mm]	5,1		7,1			9,1			
Diameter of thread $d_s$	[mm]	7,5		10,6			12,6			
Anchor size EUS2, EUSA4, EUSHCR		12			14					
Nominal embedment depth $h_{nom}$ [mm]		$h_{nom1}$	$h_{nom2}$	$h_{nom3}$	$h_{nom1}$	$h_{nom2}$	$h_{nom3}$			
		65	85	100	75	100	115			
Length of the anchor $L \leq$	[mm]	500								
Diameter of shaft $d_k$	[mm]	11,1			13,1					
Diameter of thread $d_s$	[mm]	14,6			16,6					



**Marking:**

EUS2  
Anchor size: 10  
Length of the anchor: 100  
Identification code: TSM



EUSA4  
Anchor size: 10  
Length of the anchor: 100  
Identification code: TSM  
Material: A4



EUSHCR  
Anchor size: 10  
Length of the anchor: 100  
Identification code: TSM  
Material: HCR

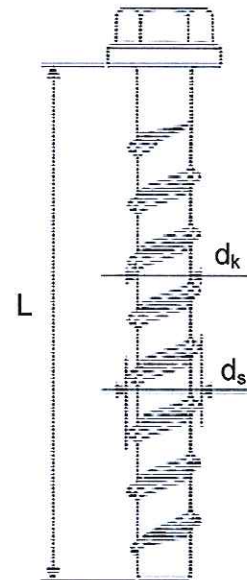

ESSVE concrete screw EUS2, EUSA4, EUSHCR

**Product descriptions**

Dimensions and markings

**Annex A 3**

## Intended use

### Anchorage subject to:

- static and quasi-static loads, all sizes and all embedment depth,
- Used for anchorages with requirements related to resistance of fire, all sizes and all embedment depth,
- used for anchorages with seismic actions category C1, sizes 8-14 for maximum embedment depth  $h_{nom3}$ .

### Base materials:

- reinforced and unreinforced concrete without fibres according to EN 206:2013,
- strength classes C20/25 to C50/60 according to EN 206:2013,
- cracked and uncracked concrete.

### Use conditions (Environmental conditions):

- The anchor may only be used in dry internal conditions: All screw types,
- Structural subject to external atmospheric exposure (including industrial and marine environment) and to permanently damp internal condition no particular aggressive conditions exists: screw types made of stainless steel with marking A4,
- Structural subject to external atmospheric exposure (including industrial and marine environment) and to permanently damp internal condition if particular aggressive conditions exists: screw types made of stainless steel with marking HCR.

Note: Such particular aggressive conditions are e.g. permanent, alternating immersion in seawater or the splash zone of seawater, chloride atmosphere of indoor swimming pools or atmosphere with chemical pollution (e.g. in desulphurization plants or road tunnels where de-icing materials are used)

### Design:

- Anchorages are designed under the responsibility of an engineer experienced in anchorages and concrete work,
- Verifiable calculation notes and drawings are prepared taking account of the loads to be anchored. The position of the anchor is indicated on the design drawings (e.g. position of the anchor relative to reinforcement or to supports, etc.),
- Anchorages are designed according to EN 1992-4:2018 and EOTA Technical Report TR 055,
- The design for shear load according to EN 1992-4:2018, Section 6.2.2 applies for all specified diameters  $d_f$  of clearance hole in the fixture in Annex B 2, Table B1.

### Installation:

- Hammer drilling only.
- Anchor installation carried out by appropriately qualified personal and under the supervision of the person responsible for technical matters of the site.
- In case of aborted hole: new drilling at a minimum distance away of twice the depth of aborted hole or smaller distance if the aborted hole is filled with high strength mortar and if under shear or oblique tension load it is not the direction of the load application.
- After installation further turning of the anchor is not possible. The head of the anchor is supported on the fixture and is not damaged.
- The drill hole may be filled with injection mortar.
- Adjustability according to Annex B 4: sizes 8-14, all anchorage depths.

ESSVE concrete screw EUS2, EUSA4, EUSHCR

Intended use

Specifications

Annex B 1

**Table B1: Installation parameters**

Anchor size EUS2, EUSA4, EUSHCR			6		8			10			
Nominal embedment depth $h_{nom}$ [mm]			$h_{nom1}$	$h_{nom2}$	$h_{nom1}$	$h_{nom2}$	$h_{nom3}$	$h_{nom1}$	$h_{nom2}$	$h_{nom3}$	
			40	55	45	55	65	55	75	85	
Nominal drill bit diameter	$d_0$	[mm]	6		8			10			
Cutting diameter of drill bit	$d_{cut} \leq$	[mm]	6,40		8,45			10,45			
Depth of drill hole	$h_1 \geq$	[mm]	45	60	55	65	75	65	85	95	
Diameter of clearing hole in the fixture	$d_f \leq$	[mm]	8		12			14			
Installation torque for version with connection thread	$T_{inst} \leq$	[Nm]	10		20			40			
Impact screw driver max. capacity		[Nm]	Max. torque according to manufacturer's instructions								
			160		300			400			
Anchor size EUS2, EUSA4, EUSHCR			12			14					
Nominal embedment depth $h_{nom}$ [mm]			$h_{nom1}$	$h_{nom2}$	$h_{nom3}$	$h_{nom1}$	$h_{nom2}$	$h_{nom3}$			
			65	85	100	75	100	115			
Nominal drill bit diameter	$d_0$	[mm]	12			14					
Cutting diameter of drill bit	$d_{cut} \leq$	[mm]	12,50			14,50					
Depth of drill hole	$h_1 \geq$	[mm]	75	95	110	85	110	125			
Diameter of clearing hole in the fixture	$d_f \leq$	[mm]	16			18					
Installation torque for version with connection thread	$T_{inst} \leq$	[Nm]	60			80					
Impact screw driver max. capacity		[Nm]	Max. torque according to manufacturer's instructions								
			650			650					

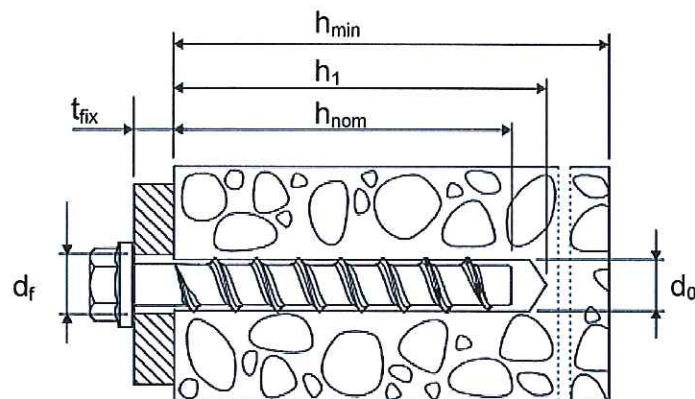

ESSVE concrete screw EUS2, EUSA4, EUSHCR

Intended use  
Installation parameters

Annex B 2

**Table B2: Minimum thickness of member, minimum edge distance and minimum spacing**

Anchor size EUS2, EUSA4, EUSHCR			6		8			10		
Nominal embedment depth $h_{nom}$ [mm]			$h_{nom1}$	$h_{nom2}$	$h_{nom1}$	$h_{nom2}$	$h_{nom3}$	$h_{nom1}$	$h_{nom2}$	$h_{nom3}$
			40	55	45	55	65	55	75	85
Minimum thickness of member	$h_{min}$	[mm]	100		100		120	100	130	130
Minimum edge distance	$c_{min}$	[mm]	40		40	50		50		
Minimum spacing	$s_{min}$	[mm]	40		40	50		50		
Anchor size EUS2, EUSA4, EUSHCR			12			14				
Nominal embedment depth $h_{nom}$ [mm]			$h_{nom1}$	$h_{nom2}$	$h_{nom3}$	$h_{nom1}$	$h_{nom2}$	$h_{nom3}$		
			65	85	100	75	100	115		
Minimum thickness of member	$h_{min}$	[mm]	120	130	150	130	150	170		
Minimum edge distance	$c_{min}$	[mm]	50		70	50	70			
Minimum spacing	$s_{min}$	[mm]	50		70	50	70			

**Installation instructions**

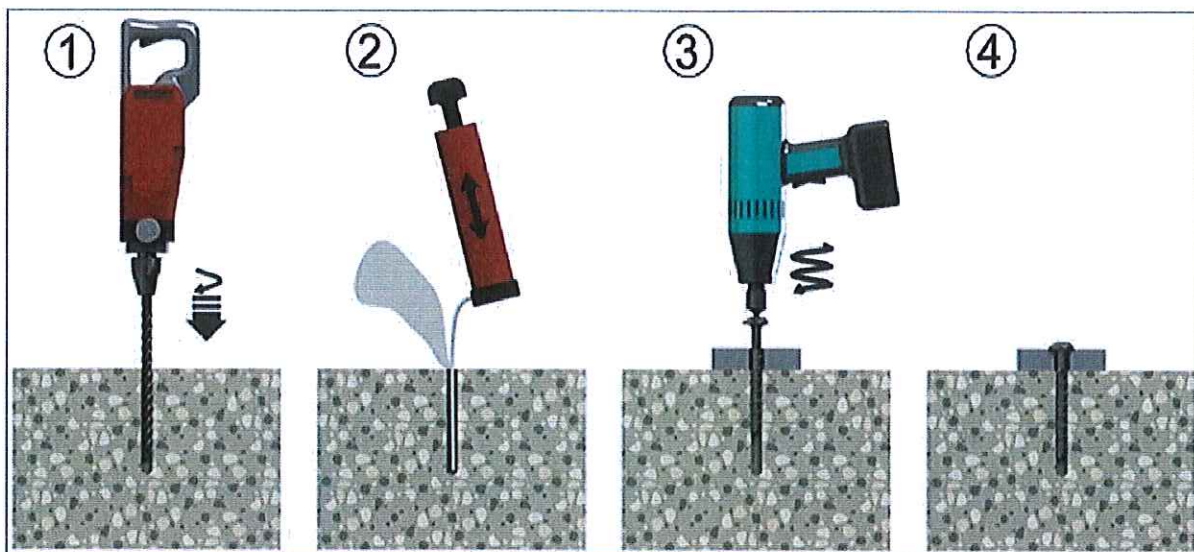

**ESSVE concrete screw EUS2, EUSA4, EUSHCR**

**Intended use**

Minimum thickness of member, minimum spacing, minimum edge distance and installation instructions

**Annex B 3**

### Installation instructions for adjustability

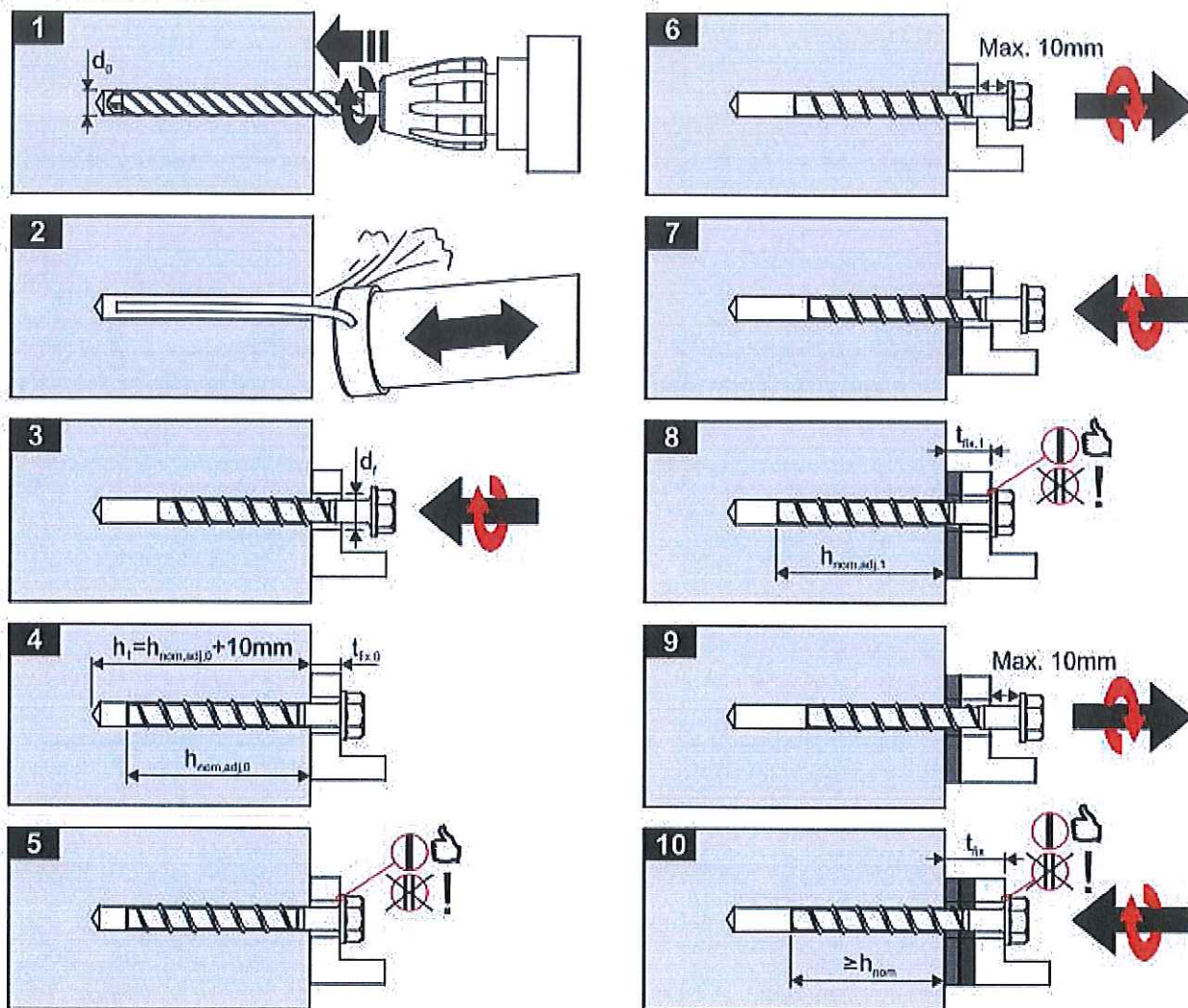

### Installation instructions

The anchor may be adjusted maximum two times while the anchor may turn back at most 10 mm.  
The total allowed thickness of shims added during the adjustment process is 10mm.  
The final embedment depth after adjustment process must be equal or larger than  $h_{nom}$ .

ESSVE concrete screw EUS2, EUSA4, EUSHCR

Intended use

Installation instruction for adjustability

Annex B 4

**Table C1: Characteristic values for design method A according to  
EN 1992-4 for anchor size 6, 8 and 10**

Anchor size EUS2, EUSA4, EUSHCR			6		8			10			
Nominal embedment depth $h_{nom}$ [mm]			$h_{nom1}$	$h_{nom2}$	$h_{nom1}$	$h_{nom2}$	$h_{nom3}$	$h_{nom1}$	$h_{nom2}$	$h_{nom3}$	
			40	55	45	55	65	55	75	85	
<b>steel failure for tension- and shear load</b>											
characteristic load	$N_{Rk,s}$	[kN]	14,0		27,0			45,0			
	$V_{Rk,s}$	[kN]	7,0		13,5		17,0	22,5		34,0	
	$k_7$	[-]	0,8		0,8			0,8			
	$M^0_{Rk,s}$	[Nm]	10,9		26,0			56,0			
<b>pull-out failure</b>											
characteristic tension load in cracked concrete C20/25	$N_{Rk,p}$	[kN]	2,0	4,0	5,0	9,0	12,0	9,0	$\geq N^0_{Rk,c}$		
characteristic tension load in uncracked concrete C20/25	$N_{Rk,p}$	[kN]	4,0	9,0	7,5	12,0	16,0	12,0	20,0	26,0	
increasing factor for $N_{Rk,p}$	$\Psi_C$	C30/37	1,22								
		C40/50	1,41								
		C50/60	1,58								
<b>concrete cone and splitting failure</b>											
effective anchorage depth	$h_{ef}$	[mm]	31	44	35	43	52	43	60	68	
factor for	cracked	$k_{cr,N}$	7,7								
	uncracked	$k_{ucr,N}$	11,0								
concrete cone failure	spacing	$s_{cr,N}$	$3 \times h_{ef}$								
	edge distance	$c_{cr,N}$	$1,5 \times h_{ef}$								
splitting failure	spacing	$s_{cr,Sp}$	120	160	120	140	150	140	180	210	
	edge distance	$c_{cr,Sp}$	60	80	60	70	75	70	90	105	
installation factor	$\gamma_{inst}$	[-]	1,0								
<b>concrete pry out failure (pry-out)</b>											
k-Factor	$k_8$	[-]	1,0						2,0		
<b>concrete edge failure</b>											
effective length of anchor	$l_f = h_{ef}$	[mm]	31	44	35	43	52	43	60	68	
outside diameter of anchor	$d_{nom}$	[mm]	6		8			10			

ESSVE concrete screw EUS2, EUSA4, EUSHCR

Performances

Characteristic values for size 6, 8 and 10

Annex C 1

**Table C2: Characteristic values for design method A according to  
EN 1992-4 for anchor size 12 and 14**

Anchor size EUS2, EUSA4, EUSHCR			12			14		
Nominal embedment depth $h_{nom}$ [mm]			$h_{nom1}$	$h_{nom2}$	$h_{nom3}$	$h_{nom1}$	$h_{nom2}$	$h_{nom3}$
			65	85	100	75	100	115
<b>steel failure for tension- and shear load</b>								
characteristic load	$N_{Rk,s}$	[kN]	67,0			94,0		
	$V_{Rk,s}$	[kN]	33,5	42,0		56,0		
	$k_7$	[-]	0,8			0,8		
	$M^0_{Rk,s}$	[Nm]	113,0			185,0		
<b>pull-out failure</b>								
characteristic tension load in cracked concrete C20/25	$N_{Rk,p}$	[kN]	12,0	$\geq N^0_{Rk,c}$		$\geq N^0_{Rk,c}$		
characteristic tension load in uncracked concrete C20/25	$N_{Rk,p}$	[kN]	16,0					
increasing factor for $N_{Rk,p}$	$\psi_c$	C30/37	1,22					
		C40/50	1,41					
		C50/60	1,58					
<b>concrete cone and splitting failure</b>								
effective anchorage depth	$h_{ef}$	[mm]	50	67	80	58	79	92
factor for	cracked	$k_{cr,N}$	7,7					
	uncracked	$k_{ucr,N}$	11,0					
concrete cone failure	spacing	$s_{cr,N}$	$3 \times h_{ef}$					
	edge distance	$c_{cr,N}$	$1,5 \times h_{ef}$					
splitting failure	spacing	$s_{cr,Sp}$	150	210	240	180	240	280
	edge distance	$c_{cr,Sp}$	75	105	120	90	120	140
installation factor	$\gamma_{inst}$	[-]	1,0					
<b>concrete pry out failure (pry-out)</b>								
k-Factor	$k_8$	[-]	1,0	2,0		1,0	2,0	
<b>concrete edge failure</b>								
effective length of anchor	$l_f = h_{ef}$	[mm]	50	67	80	58	79	92
outside diameter of anchor	$d_{nom}$	[mm]	12			14		

ESSVE concrete screw EUS2, EUSA4, EUSHCR

**Performances**

Characteristic values for size 12 and 14

**Annex C 2**

**Table C3: Displacements under tension load**

Anchor size EUS2, EUSA4, EUSHCR				6		8			10		
Nominal embedment depth $h_{nom}$ [mm]				$h_{nom1}$	$h_{nom2}$	$h_{nom1}$	$h_{nom2}$	$h_{nom3}$	$h_{nom1}$	$h_{nom2}$	$h_{nom3}$
				40	55	45	55	65	55	75	85
Cracked concrete	tension load	N	[kN]	0,95	1,9	2,4	4,3	5,7	4,3	7,9	9,6
	displacement	$\delta_{N0}$	[mm]	0,3	0,6	0,6	0,7	0,8	0,6	0,5	0,9
		$\delta_{N\infty}$	[mm]	0,4	0,4	0,6	1,0	0,9	0,4	1,2	1,2
un- cracked concrete	tension load	N	[kN]	1,9	4,3	3,6	5,7	7,6	5,7	9,5	11,9
	displacement	$\delta_{N0}$	[mm]	0,4	0,6	0,7	0,9	0,5	0,7	1,1	1,0
		$\delta_{N\infty}$	[mm]	0,4	0,4	0,6	1,0	0,9	0,4	1,2	1,2

Anchor size EUS2, EUSA4, EUSHCR				12			14		
Nominal embedment depth $h_{nom}$ [mm]				$h_{nom1}$	$h_{nom2}$	$h_{nom3}$	$h_{nom1}$	$h_{nom2}$	$h_{nom3}$
				65	85	100	75	100	115
Cracked concrete	tension load	N	[kN]	5,7	9,4	12,3	7,6	12,0	15,1
	displacement	$\delta_{N0}$	[mm]	0,9	0,5	1,0	0,5	0,8	0,7
		$\delta_{N\infty}$	[mm]	1,0	1,2	1,2	0,9	1,2	1,0
un- cracked concrete	tension load	N	[kN]	7,6	13,2	17,2	10,6	16,9	21,2
	displacement	$\delta_{N0}$	[mm]	1,0	1,1	1,2	0,9	1,2	0,8
		$\delta_{N\infty}$	[mm]	1,0	1,2	1,2	0,9	1,2	1,0

**Table C4: Displacements under shear load**

Anchor size EUS2, EUSA4, EUSHCR				6		8			10		
Nominal embedment depth $h_{nom}$ [mm]				$h_{nom1}$	$h_{nom2}$	$h_{nom1}$	$h_{nom2}$	$h_{nom3}$	$h_{nom1}$	$h_{nom2}$	$h_{nom3}$
				40	55	45	55	65	55	75	85
shear load	V	[kN]		3,3		8,6			16,2		
displacement	$\delta_{V0}$	[mm]		1,55		2,7			2,7		
	$\delta_{V\infty}$	[mm]		3,10		4,1			4,3		

Anchor size EUS2, EUSA4, EUSHCR				12			14		
Nominal embedment depth $h_{nom}$ [mm]				$h_{nom1}$	$h_{nom2}$	$h_{nom3}$	$h_{nom1}$	$h_{nom2}$	$h_{nom3}$
				65	85	100	75	100	115
shear load	V	[kN]		20,0			30,5		
displacement	$\delta_{V0}$	[mm]		4,0			3,1		
	$\delta_{V\infty}$	[mm]		6,0			4,7		

**ESSVE concrete screw EUS2, EUSA4, EUSHCR**

**Performances**

Displacements under tension and shear loads

**Annex C 3**

**Table C5: Characteristic values for seismic category C1**

Anchor size EUS2, EUSA4, EUSHCR			8	10	12	14
Nominal embedment depth $h_{nom}$ [mm]			$h_{nom3}$			
			65	85	100	115
<b>steel failure for tension- and shear load</b>						
characteristic load	$N_{Rk,s,eq}$	[kN]	27,0	45,0	67,0	94,0
	$V_{Rk,s,eq}$	[kN]	8,5	15,3	21,0	22,4
<b>pull-out failure</b>						
characteristic tension load in cracked concrete C20/25	$N_{Rk,p,eq}$	[kN]	12,0	$\geq N_{Rk,c,eq}^0$		
<b>concrete cone failure</b>						
effective anchorage depth	$h_{ef}$	[mm]	52	68	80	92
concrete spacing	$s_{cr,N}$	[mm]	$3 \times h_{ef}$			
cone failure edge distance	$c_{cr,N}$	[mm]	$1,5 \times h_{ef}$			
installation factor	$\gamma_{inst}$	[-]	1,0			
<b>concrete pry out failure (pry-out)</b>						
k-Factor	$k_B$	[-]	1,0	2,0		
<b>concrete edge failure</b>						
effective length of anchor	$l_f = h_{ef}$	[mm]	52	68	80	92
outside diameter of anchor	$d_{nom}$	[mm]	8	10	12	14

**ESSVE concrete screw EUS2, EUSA4, EUSHCR**

**Performances**

Characteristic values for seismic category C1

**Annex C 4**

**Table C6: Characteristic values of resistance to fire exposure**

Anchor size EUS2, EUSA4, EUSHCR			6		8			10			12			14		
Nominal embedment depth	$h_{nom}$		1	2	1	2	3	1	2	3	1	2	3	1	2	3
	[mm]		40	55	45	55	65	55	75	85	65	85	100	75	100	115
<b>steel failure for tension- and shear load (<math>F_{RK,s,fl} = N_{RK,s,fl} = V_{RK,s,fl}</math>)</b>																
Fire resistance class																
R30	Characteristic Resistance	$F_{RK,s,fi30}$	[kN]	0,9	2,4	4,4	7,4	10,3								
R60		$F_{RK,s,fi60}$	[kN]	0,8	1,7	3,3	5,8	8,2								
R90		$F_{RK,s,fi90}$	[kN]	0,6	1,1	2,3	4,2	5,9								
R120		$F_{RK,s,fi120}$	[kN]	0,4	0,7	1,7	3,4	4,8								
R30		$M^0_{RK,s,fi30}$	[Nm]	0,7	2,4	5,9	12,3	20,4								
R60		$M^0_{RK,s,fi60}$	[Nm]	0,6	1,8	4,5	9,7	15,9								
R90		$M^0_{RK,s,fi90}$	[Nm]	0,5	1,2	3,0	7,0	11,6								
R120		$M^0_{RK,s,fi120}$	[Nm]	0,3	0,9	2,3	5,7	9,4								
<b>edge distance</b>																
R30 - R120	$c_{cr, fi}$	[mm]	2 x $h_{ef}$													
<b>spacing</b>																
R30 - R120	$s_{cr, fi}$	[mm]	4 x $h_{ef}$													

The characteristic resistance to fire exposure for pull-out failure, concrete cone failure, concrete pry-out failure and concrete edge failure shall be calculated according to EN 1992-4. If no value for  $N_{RK,p}$  is given, in equation D.4 and D.5 value of  $N^0_{RK,c}$  shall be inserted instead of  $N_{RK,p}$ .

**ESSVE concrete screw EUS2, EUSA4, EUSHCR**

**Performances**

Characteristic values of resistance to fire exposure

**Annex C 5**

Public-law institution jointly founded by the federal states and the Federation

European Technical Assessment Body  
for construction products



## European Technical Assessment

ETA-24/1152  
of 13 January 2025

English translation prepared by DIBt - Original version in German language

### General Part

Technical Assessment Body issuing the European Technical Assessment:

Trade name of the construction product

Product family  
to which the construction product belongs

Manufacturer

Manufacturing plant

This European Technical Assessment  
contains

This European Technical Assessment is  
issued in accordance with Regulation (EU)  
No 305/2011, on the basis of

Deutsches Institut für Bautechnik

ESSVE Concrete screw EUS2, EUS A4, EUS HCR

Fasteners for use in concrete for redundant  
non-structural systems

ESSVE AB

Borgarfjordsgatan 18

SE-164 40 Kista

SCHWEDEN

ESSVE Plants

16 pages including 3 annexes which form an integral part  
of this assessment

EAD 330747-00-0601, Edition 06/2018

The European Technical Assessment is issued by the Technical Assessment Body in its official language. Translations of this European Technical Assessment in other languages shall fully correspond to the original issued document and shall be identified as such.

Communication of this European Technical Assessment, including transmission by electronic means, shall be in full. However, partial reproduction may only be made with the written consent of the issuing Technical Assessment Body. Any partial reproduction shall be identified as such.

This European Technical Assessment may be withdrawn by the issuing Technical Assessment Body, in particular pursuant to information by the Commission in accordance with Article 25(3) of Regulation (EU) No 305/2011.

## Specific Part

### 1 Technical description of the product

The ESSVE Concrete screw EUS2, EUS A4, EUS HCR of sizes 5 and 6 mm is an anchor made of galvanised steel respectively steel with zinc flake coating and of stainless steel. The anchor is screwed into a predrilled cylindrical drill hole. The special thread of the anchor cuts an internal thread into the member while setting. The anchorage is characterised by mechanical interlock in the special thread.

The product description is given in Annex A.

### 2 Specification of the intended use in accordance with the applicable EAD

The performances given in Section 3 are only valid if the anchor is used in compliance with the specifications and conditions given in Annex B.

The verifications and assessment methods on which this European Technical Assessment is based lead to the assumption of a working life of the anchor of at least 50 years. The indications given on the working life cannot be interpreted as a guarantee given by the producer, but are to be regarded only as a means for choosing the right products in relation to the expected economically reasonable working life of the works.

### 3 Performance of the product and references to the methods used for its assessment

#### 3.1 Safety in case of fire (BWR 2)

Essential characteristic	Performance
Reaction to fire	Class A1
Resistance to fire	See Annex C3

#### 3.2 Safety in use (BWR 4)

Essential characteristic	Performance
Characteristic resistance to tension load (static and quasi-static loading)	See Annex B2, Annex C1 and C2
Characteristic resistance to shear load (static and quasi-static loading)	See Annex C1 and C2
Durability	See Annex B1

### 4 Assessment and verification of constancy of performance (AVCP) system applied, with reference to its legal base

In accordance with European Assessment Document EAD No. 330747-00-0601, the applicable European legal act is: [97/161/EC].

The system to be applied is: 2+

**5 Technical details necessary for the implementation of the AVCP system, as provided for in the applicable European Assessment Document**

Technical details necessary for the implementation of the AVCP system are laid down in the control plan deposited at Deutsches Institut für Bautechnik.

Issued in Berlin on 13 January 2025 by Deutsches Institut für Bautechnik

Dipl.-Ing. Beatrix Wittstock  
Head of Section

beglaubigt:  
Tempel

## Product in installed condition

ESSVE EUS2, EUS A4, EUS HCR (size 5 and 6)

- Galvanized carbon steel
- Zinc flakes coated carbon steel

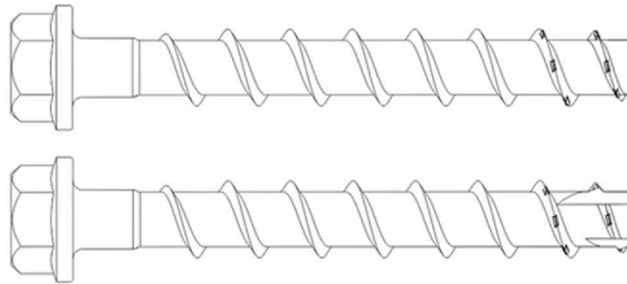

- Stainless steel A4
- High corrosion resistant steel HCR

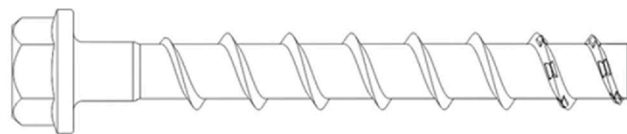
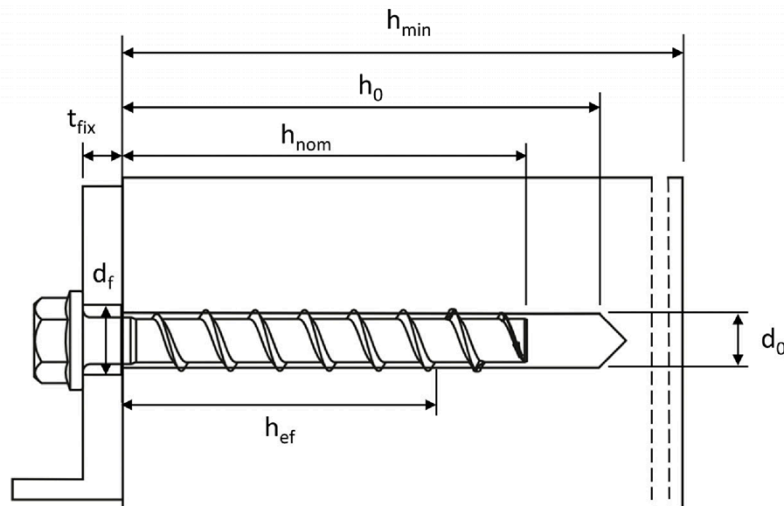

Figure illustrating concrete screw with hexagon head and fixture



$d_0$  = nominal drill hole diameter  
 $t_{fix}$  = thickness of fixture  
 $d_f$  = clearance hole diameter

$h_{min}$  = minimum thickness of member  
 $h_{nom}$  = nominal embedment depth  
 $h_0$  = drill hole depth  
 $h_{ef}$  = effective embedment depth

ESSVE Concrete screw EUS2, EUS A4, EUS HCR

**Product description**  
Product in installed condition

**Annex A1**

## Installed condition in precast prestressed hollow core slabs

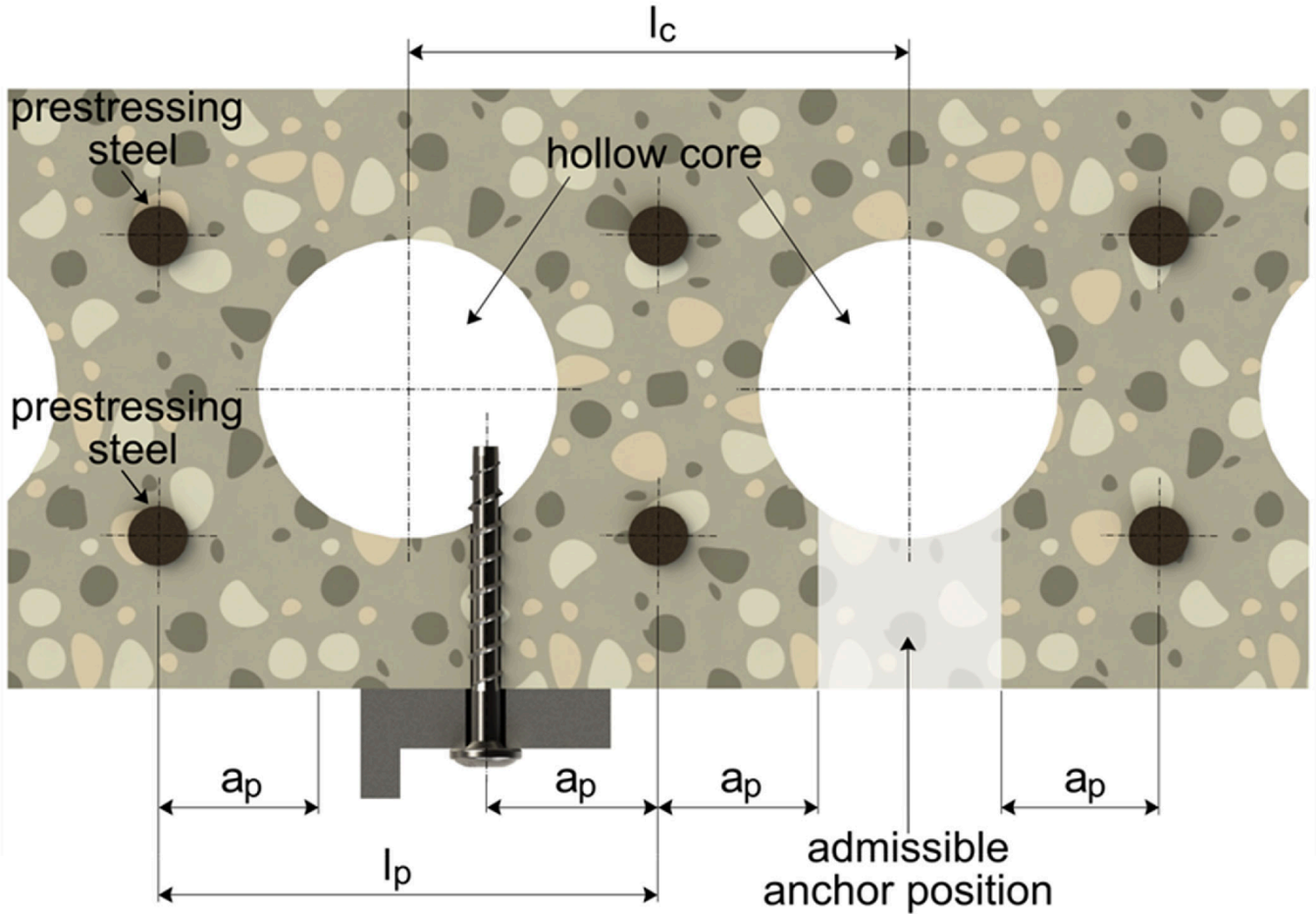

Important ratio:  $\frac{w}{e} \leq 4,2$

$w$  = core width

$e$  = web thickness

$l_c$  = core distance  $\geq 100$  mm

$l_p$  = prestressing steel  $\geq 100$  mm

















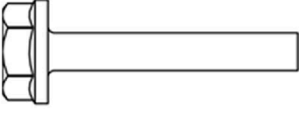

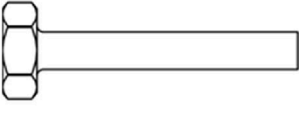

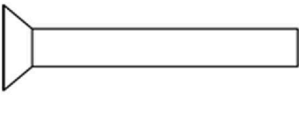

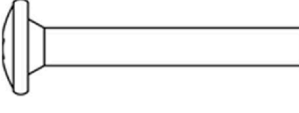
$a_p$  = distance between anchor position and prestressing steel  $\geq 50$ mm

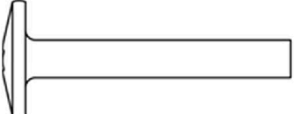
ESSVE Concrete screw EUS2, EUS A4, EUS HCR

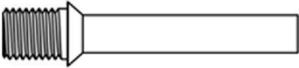
### Product description

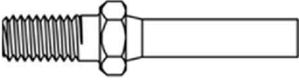
Installed condition in precast prestressed hollow core slabs

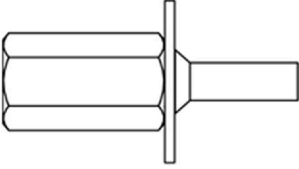
Annex A2

		1. Configuration with metric connection thread and hexagon socket e.g. EUS2 8x105 M10 SW5
		2. Configuration with metric connection thread and hexagon drive e.g. EUS2 8x105 M10 SW7
		3. Configuration with washer and hexagon head e.g. EUS2-HF 8x80 SW13
		4. Configuration with washer, hexagon head and TORX drive e.g. EUS2-HF 8x80 SW13 TX40
		5. Configuration with hexagon head e.g. EUS2-H 8x80 SW13
		6. Configuration with countersunk head and TORX drive e.g. EUS2-C 8x80 C TX40
		7. Configuration with pan head and TORX drive e.g. EUS2-PS 8x80 TX40
		8. Configuration with large pan head and TORX drive e.g. EUS2-PL 8x80 TX40
		9. Configuration with countersunk head and connection thread e.g. EUS2-E 6x55 M8
		10. Configuration with hexagon drive and connection thread e.g. EUS2-E 6x55 M8 SW10
		11. Configuration with internal thread and hexagon drive e.g. EUS2-I 6x55 M8/10

ESSVE Concrete screw EUS2, EUS A4, EUS HCR

**Product description**  
Screw types

**Annex A3**

Table 1: Material

Part	Product name	Material
all types	EUS2	- Steel EN 10263-4:2017 galvanized acc. to EN ISO 4042:2018 - Zinc flake coating according to EN ISO 10683:2018 ( $\geq 5\mu\text{m}$ )
	EUS A4	1.4401; 1.4404; 1.4571; 1.4578
	EUS HCR	1.4529

Part	Product name	Nominal characteristic steel		Rupture elongation $A_5$ [%]
		Yield strength $f_{yk}$ [N/mm <sup>2</sup> ]	Ultimate strength $f_{uk}$ [N/mm <sup>2</sup> ]	
all types	EUS2	560	700	$\leq 8$
	EUS A4			
	EUS HCR			

Table 2: Dimensions

Anchor size			5	6
Screw length	$\leq L$	[mm]	200	
Core diameter	$d_k$	[mm]	4,0	5,1
Thread outer diameter	$d_s$	[mm]	6,5	7,5

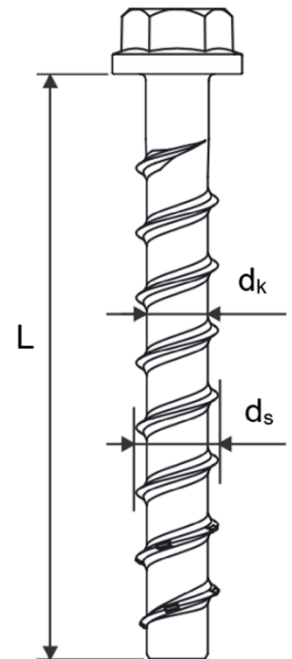

**Marking:**

**EUS2**

Screw type: TSM  
Screw size: 10  
Screw length: 100



**EUS A4**

Screw type: TSM  
Screw size: 10  
Screw length: 100  
Material: A4

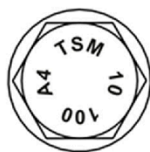

**EUS HCR**

Screw type: TSM  
Screw size: 10  
Screw length: 100  
Material: HCR



**Marking "k" or "x"**

for anchors with connection thread and  $h_{nom} = 35\text{mm}$

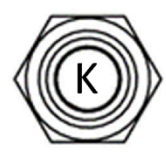

ESSVE Concrete screw EUS2, EUS A4, EUS HCR

**Product description**  
Material, Dimensions and markings

**Annex A4**

## Specification of Intended use

### Anchorage subject to:

- static and quasi static loads
- Used only for multiple use for non-structural application according to EN 1992-4:2018
- Used for anchorages with requirements related to resistance of fire (not for using in prestressed hollow core slabs): size 5 and 6
- Used for anchorages in prestressed hollow core slabs: size 6

### Base materials:

- Compacted reinforced and compacted unreinforced concrete without fibers according to EN 206:2013.
- Strength classes C20/25 to C50/60 according to EN 206:2013.
- Cracked and uncracked concrete.

### Use conditions (Environmental conditions):

- Concrete screws subject to dry internal conditions: all screw types.
- For all other conditions corresponding to corrosion resistance classes CRC according to EN 1993-1-4:2006 + A1:2015
  - Stainless steel according to Annex A4, screw with marking A4: CRC III
  - High corrosion resistant steel according to Annex A4, screw with marking HCR: CRC V

### Design:

- Anchorages are to be designed under the responsibility of an engineer experienced in anchorages and concrete work.
- Verifiable calculation notes and drawings are to be prepared taking account of the loads to be anchored. The position of the anchor is indicated on the design drawings (e.g. position of the anchor relative to reinforcement or to supports, etc.).
- Anchorages are designed according to EN 1992-4:2018 and EOTA Technical Report TR 055, Version February 2018.
- The design for shear load according to EN 1992-4:2018, Section 6.2.2 applies for all specified diameters  $d_f$  of clearance hole in the fixture in Annex B2, Table 3.

### Installation:

- Hammer drilling or hollow drilling.
- Anchor installation carried out by appropriately qualified personal and under the supervision of the person responsible for technical matters on site.
- In case of aborted hole: new drilling must be drilled at a minimum distance of twice the depth of aborted hole or closer, if the aborted hole is filled with high strength mortar and only if the hole is not in the direction of the oblique tensile or shear load.
- After installation further turning of the anchor must not be possible. The head of the anchor is supported in the fixture and is not damaged.

**ESSVE Concrete screw EUS2, EUS A4, EUS HCR**

**Intended use  
Specification**

**Annex B1**

Table 3: Installation parameters

Concrete screw size			5	6	
Nominal embedment depth	$h_{nom}$		$h_{nom1}$	$h_{nom1}$	$h_{nom2}$
	[mm]		35	35	55
Nominal drill hole diameter	$d_0$	[mm]	5	6	
Cutting diameter of drill bit	$d_{cut} \leq$	[mm]	5,40	6,40	
Drill hole depth	$h_0 \geq$	[mm]	40	40	60
Clearance hole diameter	$d_f \leq$	[mm]	7	8	
Installation torque (version with connection thread)	$T_{inst} \leq$	[Nm]	8	10	
Recommended torque impact screw driver		[Nm]	Max. torque according to manufacturer's instructions		
			110	160	

Table 4: Minimum thickness of member, minimum edge distance and minimum spacing

Concrete screw size			5	6	
Nominal embedment depth	$h_{nom1}$		$h_{nom1}$	$h_{nom1}$	$h_{nom2}$
	[mm]		35	35	55
Minimum thickness of member	$h_{min}$	[mm]	80	80	100
Minimum edge distance	$c_{min}$	[mm]	35	35	40
Minimum spacing	$s_{min}$	[mm]	35	35	40

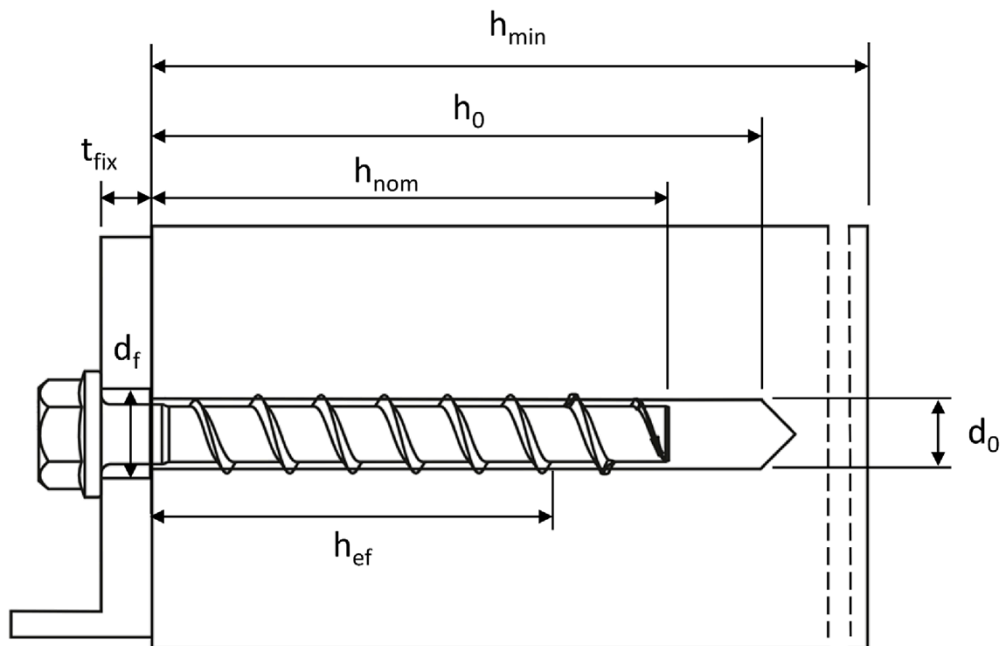

ESSVE Concrete screw EUS2, EUS A4, EUS HCR

Intended use  
Installation parameters

Annex B2

### Installation parameters for anchorages in precast prestressed hollow core slabs

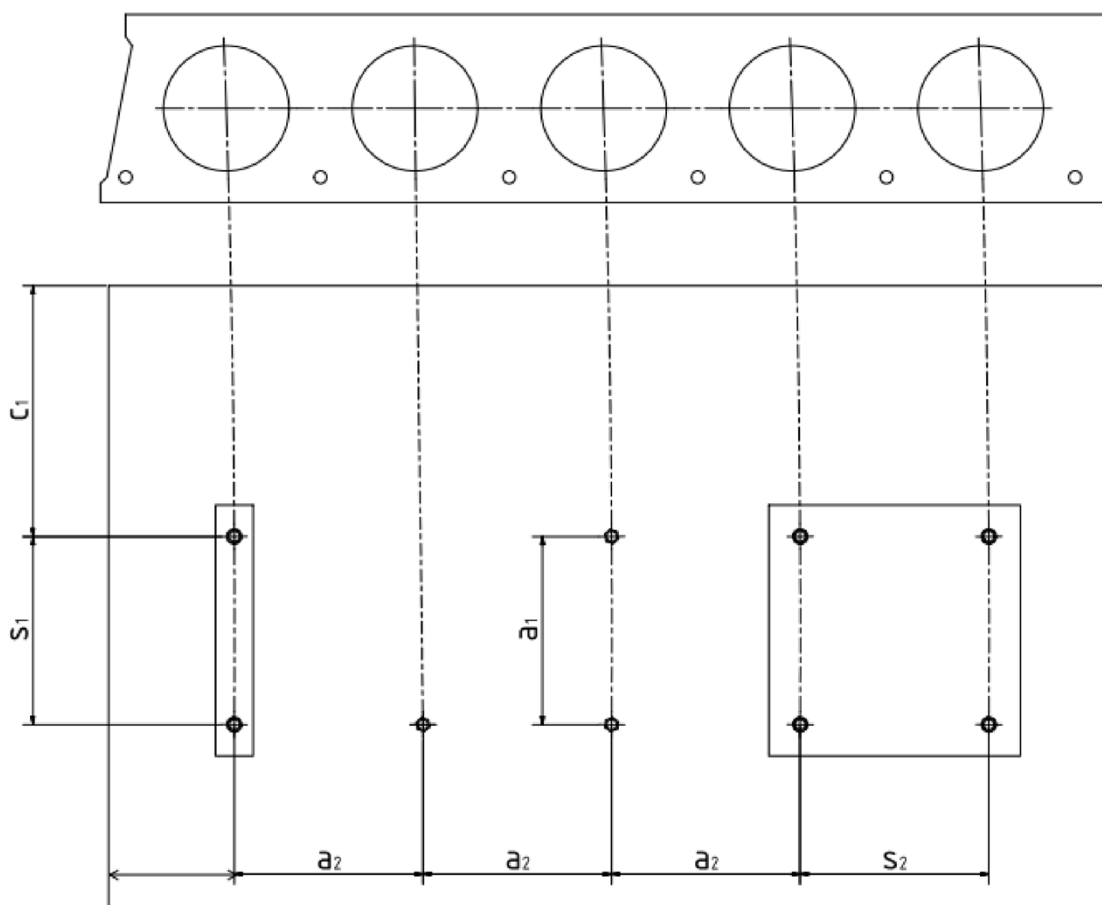

$c_1, c_2$  = edge distance

$s_1, s_2$  = anchor spacing

$a_1, a_2$  = distance between anchor groups

$c_{min}$  = minimum edge distance  $\geq 100$  mm

$s_{min}$  = minimum anchor spacing  $\geq 100$  mm

$a_{min}$  = minimum distance between anchor groups  $\geq 100$  mm

**ESSVE Concrete screw EUS2, EUS A4, EUS HCR**

**Intended use**

Installation parameters for anchorages in precast prestressed hollow slabs

**Annex B3**

## Installation Instructions

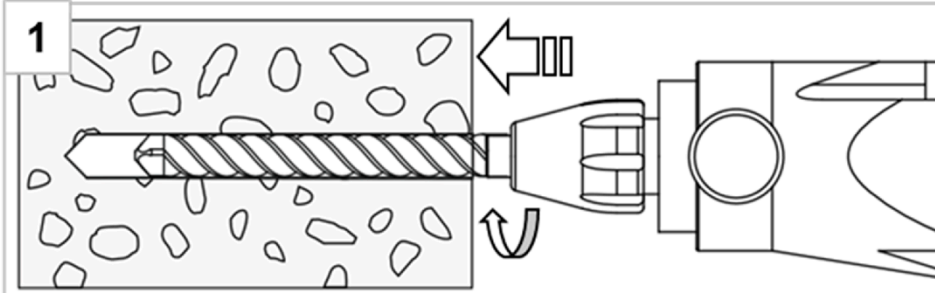
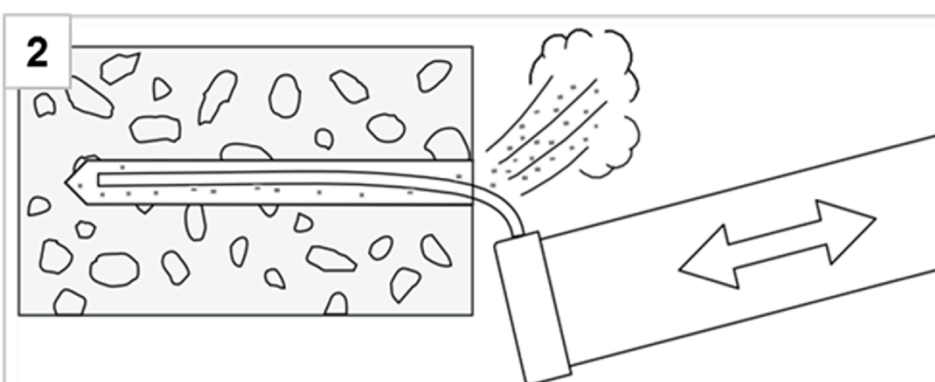
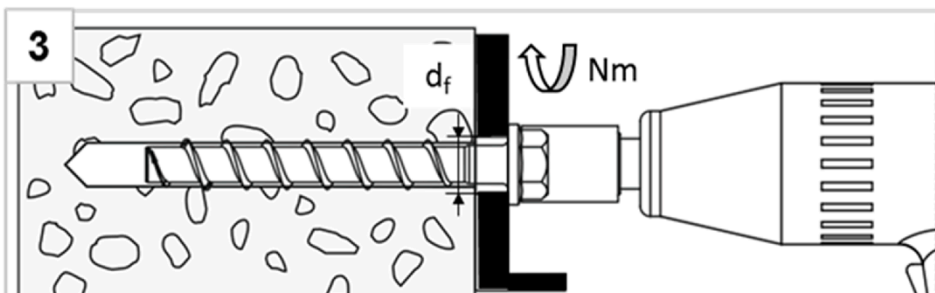
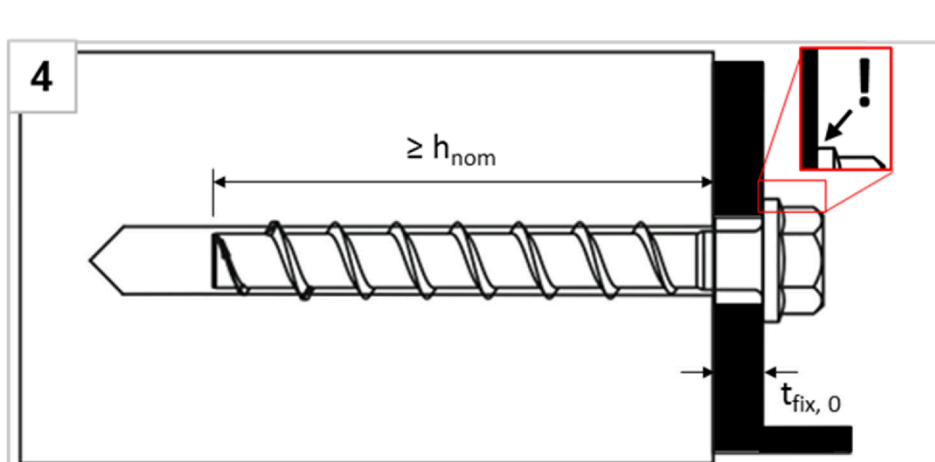
<p><b>1</b></p> 	<p>Create hammer drilled or hollow drilled borehole</p>
<p><b>2</b></p> 	<p>Remove drill dust by vacuuming or blowing of</p>
<p><b>3</b></p> 	<p>Install with torque impact screw driver or torque wrench</p>
<p><b>4</b></p> 	<p>The head must be undamaged and in contact with the fixture</p>

ESSVE Concrete screw EUS2, EUS A4, EUS HCR

**Intended use**  
Installation instructions

**Annex B4**

## Installation Instructions for anchorages in prestressed hollow slabs

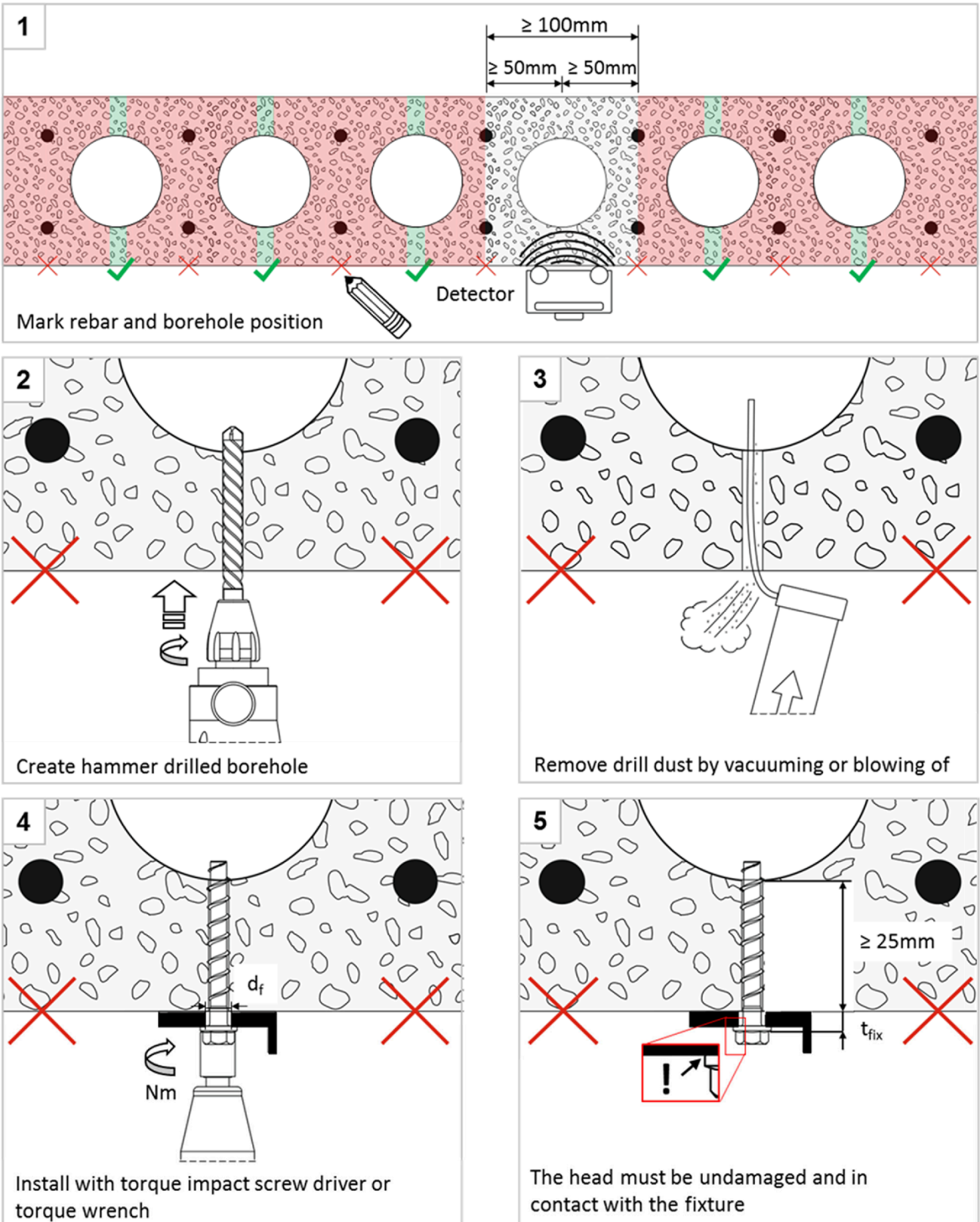

ESSVE Concrete screw EUS2, EUS A4, EUS HCR

**Intended use**  
Installation instructions for anchorages in prestressed hollow slabs

**Annex B5**

Table 5: Characteristic values for static and quasi-static loading

Concrete screw size			5	6		
Nominal embedment depth	$h_{nom}$		$h_{nom1}$	$h_{nom1}$	$h_{nom2}$	
	[mm]		35	35	55	
<b>Steel failure for tension and shear loading</b>						
Characteristic tension load	$N_{Rk,s}$	[kN]	8,7	14,0		
Partial factor	$\gamma_{Ms,N}$	[-]	1,5			
Characteristic shear load	$V_{Rk,s}$	[kN]	4,4	7,0		
Partial factor	$\gamma_{Ms,V}$	[-]	1,25			
Ductility factor	$k_7$	[-]	0,8			
Characteristic bending load	$M^0_{Rk,s}$	[Nm]	5,3	10,9		
<b>Pull-out failure</b>						
Characteristic tension load C20/25	cracked	$N_{Rk,p}$	[kN]	1,5	3,0	7,5
	uncracked	$N_{Rk,p}$	[kN]	1,5	3,0	7,5
Increasing factor for $N_{Rk,p} = N_{Rk,p(C20/25)} * \psi_c$	C25/30	$\psi_c$	[-]	1,12		
	C30/37			1,22		
	C40/50			1,41		
	C50/60			1,58		
<b>Concrete failure: Splitting failure, concrete cone failure and pry-out failure</b>						
Effective embedment depth	$h_{ef}$	[mm]	27	27	44	
k-factor	cracked	$k_1 = k_{cr}$	[-]	7,7		
	uncracked	$k_1 = k_{ucr}$	[-]	11,0		
Concrete cone failure	spacing	$s_{cr,N}$	[mm]	$3 \times h_{ef}$		
	edge distance	$c_{cr,N}$	[mm]	$1,5 \times h_{ef}$		
Splitting failure	resistance	$N^0_{Rk,Sp}$	[kN]	$\min(N^0_{Rk,c}; N_{Rk,p})$		
	spacing	$s_{cr,Sp}$	[mm]	120	120	160
	edge distance	$c_{cr,Sp}$	[mm]	60	60	80
Factor for pry-out failure	$k_8$	[-]	1,0			
Installation factor	$\gamma_{inst}$	[-]	1,2	1,0	1,0	
<b>Concrete edge failure</b>						
Effective length in concrete	$l_f = h_{ef}$	[mm]	27	27	44	
Nominal outer diameter of screw	$d_{nom}$	[mm]	5	6		

ESSVE Concrete screw EUS2, EUS A4, EUS HCR

**Performances**  
Characteristic values for static and quasi-static loading

**Annex C1**

**Table 6: Characteristic values of resistance in precast prestressed hollow core slabs C30/37 to C50/60**

Concrete screw size			6		
Bottom flange thickness	$d_b$	[mm]	$\geq 25$	$\geq 30$	$\geq 35$
Characteristic resistance	$F_{Rk}^0$	[kN]	1	2	3
Edge distance	$c_{cr}$	[mm]	100		
Spacing	$s_{cr}$	[mm]	200		
Installation factor	$\gamma_{inst}$	[-]	1,0		

**Table 7: Limiting distances for application in precast prestressed hollow core slabs**

Distances for application in precast prestressed hollow core slabs			
Minimum edge distance	$c_{min}$	[mm]	$\geq 100$
Minimum anchor spacing	$s_{min}$	[mm]	$\geq 100$
Minimum distance between anchor groups	$a_{min}$	[mm]	$\geq 100$
Distance of core	$l_c$	[mm]	$\geq 100$
Distance of prestressing steel	$l_p$	[mm]	$\geq 100$
Distance between anchor position and prestressing steel	$a_p$	[mm]	$\geq 50$

**ESSVE Concrete screw EUS2, EUS A4, EUS HCR**

**Performances**

Characteristic values and limiting distances in precast prestressed hollow core slabs

**Annex C2**

Table 8: Fire exposure – characteristic values of resistance <sup>1)</sup>

Concrete screw size				5		6		
Material				EUS2		EUS2		EUS A4/HCR
Nominal embedment depth		h <sub>nom</sub>		h <sub>nom1</sub>	h <sub>nom1</sub>	h <sub>nom2</sub>	h <sub>nom1</sub>	h <sub>nom2</sub>
		[mm]		35	35	55	35	55
Steel failure for tension and shear load ( $F_{Rk,s,fi} = N_{Rk,s,fi} = V_{Rk,s,fi}$ )								
Characteristic Resistance	R30	$F_{Rk,s,fi30}$	[kN]	0,8	0,9	1,2		
	R60	$F_{Rk,s,fi60}$	[kN]	0,6	0,8	1,2		
	R90	$F_{Rk,s,fi90}$	[kN]	0,4	0,6	1,2		
	R120	$F_{Rk,s,fi120}$	[kN]	0,3	0,4	0,8		
	R30	$M^0_{Rk,s,fi30}$	[Nm]	0,5	0,7	0,9		
	R60	$M^0_{Rk,s,fi60}$	[Nm]	0,4	0,6	0,9		
	R90	$M^0_{Rk,s,fi90}$	[Nm]	0,2	0,5	0,9		
	R120	$M^0_{Rk,s,fi120}$	[Nm]	0,2	0,3	0,6		
Pull-out failure								
Characteristic Resistance	R30-R90	$N_{Rk,p,fi}$	[kN]	0,375	0,75	1,875	0,75	1,875
	R120	$N_{Rk,p,fi}$	[kN]	0,3	0,6	1,5	0,6	1,5
Concrete cone failure								
Characteristic Resistance	R30-R90	$N^0_{Rk,c,fi}$	[kN]	0,65	0,65	2,21	0,65	2,21
	R120	$N^0_{Rk,c,fi}$	[kN]	0,52	0,52	1,76	0,52	1,76
Edge distance								
R30 - R120		$C_{cr,fi}$	[mm]	2 x h <sub>ef</sub>				
In case of fire attack from more than one side, the minimum edge distance shall be ≥300mm.								
Spacing								
R30 - R120		$S_{cr,fi}$	[mm]	4 x h <sub>ef</sub>				
Pry-out failure								
R30 - R120		$k_g$	[-]	1,0				
The anchorage depth has to be increased for wet concrete by at least 30 mm compared to the given value.								

<sup>1)</sup> Not for application in prestressed hollow core slabs

ESSVE Concrete screw EUS2, EUS A4, EUS HCR

**Performances**  
Characteristic values under fire exposure

**Annex C3**